

# HOWLER<sup>®</sup>

*We Sound your Road<sup>®</sup>*

## SUBWOOFER 6.5", 8", 10" AND 12" SMART SERIES

MODEL	H8W-06	H8W-08	H8W-10	H8W-12
<b>Specifications</b>				
NOMINAL DUAL IMPEDANCE	DUAL 4Ω	Dual 4Ω / 2Ω	Dual 4Ω / 2Ω	Dual 4Ω / 2Ω
Voice Coil Diameter	1.5"	2"	2.5"	3"
Voice Coil Height	23MM	30MM	35MM	35MM
HE Magnetic Gap Height	8MM	8MM	10MM	10MM
Max. Linear Excursion ONE WAY	7.5MM	11MM	12.5MM	12.5MM
Voice Coil Wire	COPPER	COPPER	COPPER	COPPER
Number Of Layers	4	4	4	4
Magnet System Type	Y35 40oz	y35 40x2oz	y35 2x50oz	y35 2x60oz
BI Produc	11	15.8		
POWER HANDLING RMS	300w	400w	600w	800w
POWER HANDLING PEAK	600w	800w	1200w	1600w
NOMEX DUAL SPIDER	yes	yes	yes	yes

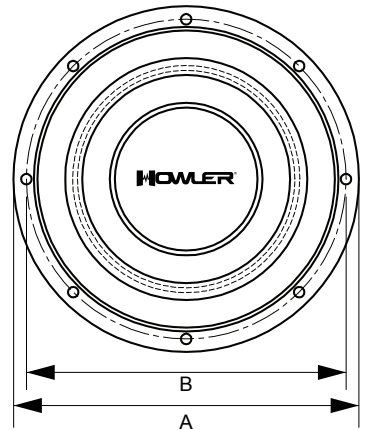

MODEL	H8W-06		H8W-08		H8W-10		H8W-12	
<b>T-S Parameters</b>								
NOMINAL DUAL IMPEDANCE	D4Ω	D4Ω	D2Ω	D4Ω	D2Ω	D4Ω	D2Ω	D2Ω
Free Air resonance	60	40	37	41	40	35	34	
IMP	4x2	4x2	2x2	4x2	2x2	4x2	2x2	
RE	6.4	6.4	3.8	6.4	3.8	6.4	3.8	
MMS	52.4	108	120	108	128	246	266	
CMS	0.14	0.14	0.13	0.14	0.12	0.08	0.08	
BL	13.2	15.8	13.5	15.8	13.3	21.3	17.5	
Electrical "Q"	(Qes) 0.72	0.71	0.67	0.71	0.7	0.76	0.71	
Mechanical "Q"	(Qms) 6.98	5.86	5.86	5.66	5.66	6.35	6.35	
Total Speaker.	(Qts) 0.58	0.63	0.59	0.63	0.56	0.68	0.6	
Equivalent Compliance.	(Vas) 3.88	7.6	7.1	7.5	18.9	33.1	30.5	
One-Way Linear Excursion.	(Xmax) 7.5	11	11	12.5	12.5	12.5	12.5	
Resonance Efficiency.	(No) -	-	-	-	-	-	-	
Effective Piston area.	(Sd) -	-	-	-	-	-	-	
Spl(dB@1w/1m)	83	81		84.5		85	83	
Mounting Depth.	(mm) 107	128		145		157	157	
Mounting hole Diameter.	(mm) φ145	φ185		φ232		φ282	φ282	

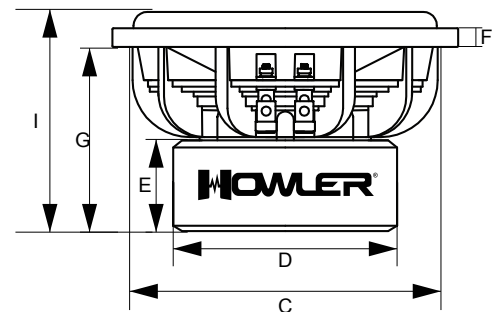

MODEL	H8W-06		H8W-08		H8W-10		H8W-12	
<b>Dimensions (mm)</b>								
Woofer Diameter	A	179	213	274	317			
Mounting Diameter	B	163	197	259	297			
Mounting Diameter	C	151	188	238	260			
Magnet Diameter	D	130	140	162	176			
Motor Depth	E	47	56	58	58			
Gasket Depth	F	13.5	14.5	16	18			
Mounting Depth	G	102	116	134	146			
Surround	H	146	182	228	280			
Mounting Depth Surround	I	124	137	160	174			



 33 1260 1857



### CONSIDERACIONES DE USO

La exposición continua de niveles de presión sonora por encima de 100 dB puede ser causa de pérdida de audición permanente. Sistemas de sonido de alta potencia puede producir niveles de presión sonora por encima de 130dB. Usa el sentido común y disfruta de un sonido seguro.

# GARANTÍA LIMITADA

**Antes de enviar este producto para servicio o para un número de autorización de devolución. Este número debe estar claramente marcado en la parte exterior de la caja.**

Términos y condiciones: Howler Sound garantiza que la unidad está libre de cualquier defecto en el material o defectos de fabricación por un período de 90 días, y se compromete a reparar esta unidad o cualquier parte de la misma sólo si se demuestra que esta defectuosa como resultado del uso normal. Con la finalidad de recibir el servicio de garantía de este producto, el propietario debe registrarse con prontitud rellenando y enviando por correo la tarjeta de registro de garantía.

Nuestra obligación bajo esta garantía se limita a reparar sólo los componentes defectuosos de la unidad de la misma cuando es devuelto, prepago para envío a howler Sound.

Esta garantía debe ser considerada nula si la unidad ha sido manipulada, contrariamente conectada con las instrucciones de instalación en el manual del propietario, alterada, dañada por tensiones de entrada indebidas o polaridad o tratada de manera negligente.

La garantía fuera de servicio está disponible después de la expiración de la garantía regular. El costo de la reparación se basa en las tasas actuales de mano de obra de reparación, empaque la unidad de manera segura y enviarla prepagada y asegurada a la dirección plasmada debajo. Howler Sound no será responsable de los daños sufridos durante el envío.

# LIMITED WARRANTY

**Before shipping this product back for service call for a Return Authorization number. This number must be clearly marked on the outside of the box.**

Terms & Conditions: Howler Sound warrants the unit to be free of any material defects or defects in workmanship for a period of one year and will repair this unit or any part thereof only if it proves to be defective as a result of normal use. In order to receive warranty service on this product, the owner must promptly register by filling in and mailing the Warranty Registration Card.

Our obligation under this warranty is limited to repairing only the defective components of the unit thereof when it is returned, shipping prepaid, to Howler Sound.

This warranty is to be considered void if the unit has been tampered with, connected contrary to the installation instructions in the owner's manual, altered, damaged by improper input voltages or polarity, defaced, or treated in a negligent manner.

Out of warranty service is available after the warranty expires. Cost of repair is based on current repair labor rates, plus the cost of shipping and handling. When returning for repair, pack the unit securely and send prepaid and insured to the address



 [facebook.com/Howlersound](https://facebook.com/Howlersound)

 [@HowlerSound](https://twitter.com/HowlerSound)

 [@HowlerSound](https://www.instagram.com/HowlerSound)

[technical-support@howlersound.com](mailto:technical-support@howlersound.com)

[www.howlersound.com](http://www.howlersound.com)

01 800 1 **HSOUND**  
4 7 0 8 6 3